

CT Manual Test Stand

Basic Force Measurement Test Stand

DILLON

precisely

precision

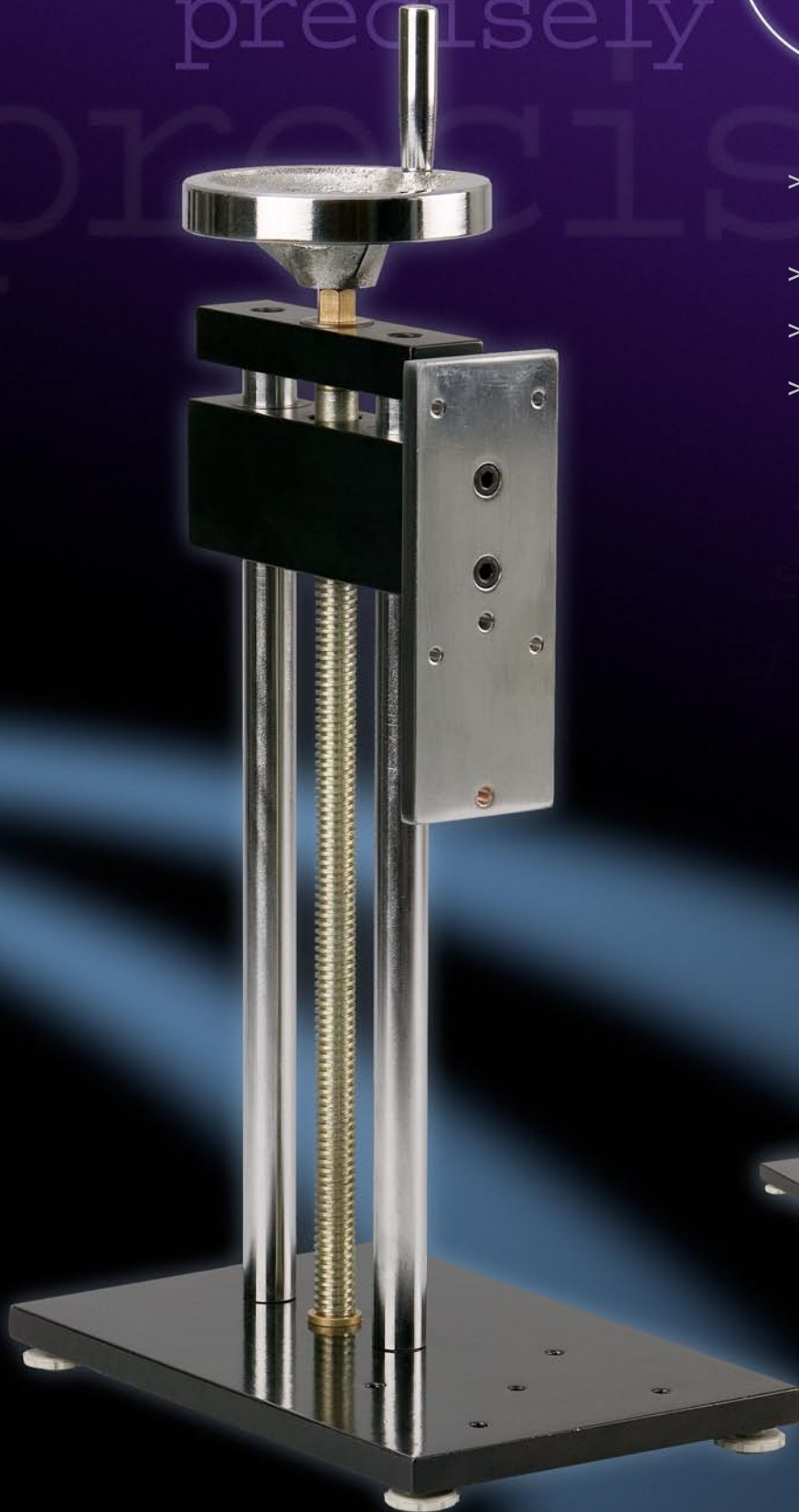

- > Applies Tension and Compression Loads
- > Improves testing consistency
- > Ultra-affordable
- > Accommodates Dillon and competitive force gauges



Optional Dillon Model GL digital force gauge.

The Dillon CT Test Stand is an affordable tool to improve the quality of testing results. It controls the variables which can affect testing results, including.

- > Off axis forces – Maintains alignment with the force gauge axis
- > Speed variations – Reduces ‘force surges’ that are common in handheld tests

Aligns with the Model GL force gauge without accessories. The tension alignment accessory permits other gauges to be used in tension in perfect alignment.

Specifications:

Capacity: 500 N / 110 lbf / 50 kgf

Tension/Compression testing:
Both

Travel per hand wheel rotation:
3.0 mm / 0.12 in

Gauge mounting: All Dillon electronic force gauges and other gauges with the popular 2.25 inch (57 mm) spacing attach to crosshead. Plate may be drilled to accommodate other patterns.

Warranty: One year parts and labor.

Shipping weight: 8 kg (18 lb)

Accessories:

Tension alignment accessory:

Adjustable front to rear. M6 and 10-32 mounting threads.



Dimensions

UNITS:
millimeters (inches)

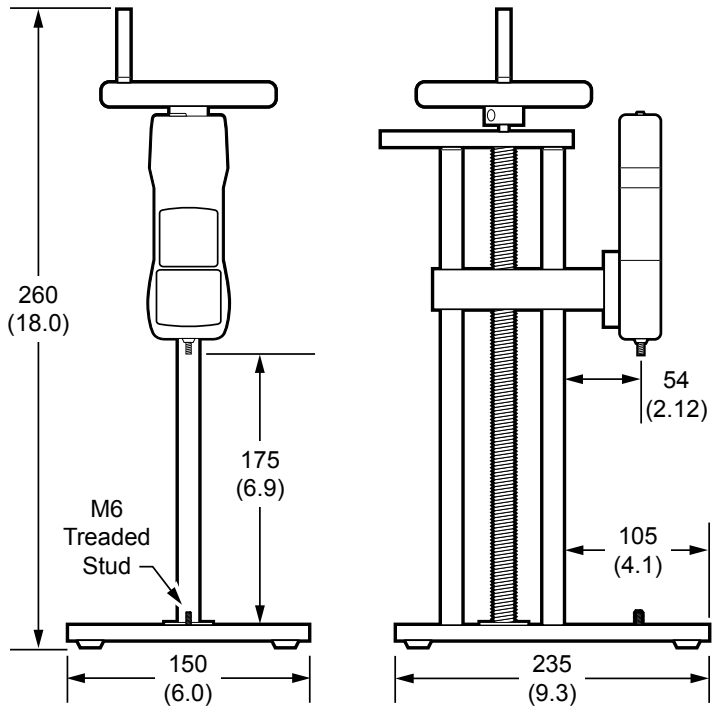

AUTHORIZED DISTRIBUTORS

Ask the experts. Dillon distributors offer complete service capabilities from application assistance to sales and product support. Their experienced representatives are the most knowledgeable experts that you will find in the force measurement industry. We recommend that you consult these capable specialists for all of your measuring needs.

DILLON

Force Measurement Instruments

Dillon/Quality Plus, Inc.
Distributor/Sales/Service/Calibration

Toll-Free: (800) 493-2263
email: dan@dqplus.com
Fax: (816-453-7677

www.dqplus.com

